

Amhaze ECO

User Manual



Model ID: (120V): AMHAZEECO
Model ID: (220V): 220VAMHAZEECO

CHAUVET
PROFESSIONAL

1. Edition Notes

The AmHaze ECO User Manual includes a description, safety precautions, installation, programming, operation, and maintenance instructions for the AmHaze ECO as of the release of this edition.

Trademarks

Chauvet, Chauvet Professional, the Chauvet logo, and Amhaze are registered trademarks or trademarks of Chauvet & Sons, LLC (d/b/a Chauvet and Chauvet Lighting) in the United States and other countries. Other company and product names and logos referred to herein may be trademarks of their respective companies.

Copyright Notice

The works of authorship contained in this manual, including, but not limited to, all designs, text, and images are owned by Chauvet.

© **Copyright 2023 Chauvet & Sons, LLC. All rights reserved.**

Electronically published by Chauvet in the United States of America.

Manual Use

Chauvet authorizes its customers to download and print this manual for professional information purposes only. Chauvet expressly prohibits the usage, copy, storage, distribution, modification, or printing of this manual or its content for any other purpose without written consent from Chauvet.

Document Printing

For best results, print this document in color, on letter size paper (8.5 x 11 in), double-sided. If using A4 paper (210 x 297 mm), configure the printer to scale the content accordingly.

Intended Audience

Any person installing, operating, and/or maintaining this product should completely read through the guide that shipped with the product, as well as this manual, before installing, operating, or maintaining this product.

Disclaimer

Chauvet believes that the information contained in this manual is accurate in all respects. However, Chauvet assumes no responsibility and specifically disclaims any and all liability to any party for any loss, damage, or disruption caused by any errors or omissions in this document, whether such errors or omissions result from negligence, accident, or any other cause. Chauvet reserves the right to revise the content of this document without any obligation to notify any person or company of such revision, however, Chauvet has no obligation to make, and does not commit to make, any such revisions. Download the latest version from www.chauvetprofessional.com.

Document Revision

This AmHaze ECO User Manual is the 3rd edition of this document. Go to www.chauvetprofessional.com for the latest version.

TABLE OF CONTENTS

1. Edition Notes	1
Trademarks	1
Copyright Notice.....	1
Manual Use	1
Document Printing.....	1
Intended Audience	1
Disclaimer	1
Document Revision	1
1. Before You Begin	1
What Is Included	1
Claims	1
Text Conventions	1
Symbols	1
Safety Notes.....	2
Personal Safety	2
Mounting and Rigging	2
Power and Wiring	2
Operation	2
2. Introduction.....	3
Description	3
Features	3
Product Overview.....	3
Product Dimensions	3
3. Setup.....	4
AC Power	4
AC Plug	4
Resetting the Breaker	4
DMX Linking.....	4
DMX Personalities.....	4
Remote Device Management (RDM).....	4
Mounting	5
Orientation.....	5
Rigging	5
Procedure.....	5
4. Operation.....	6
Control Panel Description	6
Control Options	6
Programming.....	6
Menu Map	6
RDM Chart	7
Configuration (DMX)	9
Starting Address.....	9
Control Channel Assignments and Values.....	9
3-Channel	9
Configuration (Standalone)	9
Haze Output.....	9
Fan Speed.....	9
Timer Interval	9
Timer Duration	9
Configuration (Settings)	10
RDM-UID	10
Fluid Sensor.....	10
Auto Run Last Setting.....	10

Auto Shutdown.....	10
Priming the Pump.....	10
5. Maintenance.....	11
Product Maintenance	11
Storage.....	11
6. Technical Specifications.....	12
Contact Us.....	13
Warranty & Returns.....	13

Before You Begin

1. Before You Begin

What Is Included

- AmHaze ECO
- Seetronic Powerkon IP65 power cable
- Quick Reference Guide

Claims

Carefully unpack the product immediately and check the container to make sure all the parts are in the package and are in good condition.



If the box or the contents (the product and included accessories) appear damaged from shipping, or show signs of mishandling, notify the carrier immediately, not Chauvet. Failure to report damage to the carrier immediately may invalidate the claim. In addition, keep the box and contents for inspection.

For other issues, such as missing components or parts, damage not related to shipping, or concealed damage, file a claim with Chauvet within 7 days of delivery.

Text Conventions

Convention	Meaning
1–512	A range of values
50/60	A set of values of which only one can be chosen
Settings	A menu option not to be modified
<ENTER>	A key to be pressed on the product's control panel

Symbols

Symbol	Meaning
	Critical installation, configuration, or operation information. Not following these instructions may make the product not work, cause damage to the product, or cause harm to the operator.
	Important installation or configuration information. The product may not function correctly if this information is not used.
	Useful information.



The term “DMX” used throughout this manual refers to the USITT DMX512-A digital data transmission protocol.

Safety Notes

Read all the following safety notes before working with this product. These notes contain important information about the installation, usage, and maintenance of this product.



This product contains no user-serviceable parts. Any reference to servicing in this User Manual will only apply to properly trained, certified technicians. Do not open the housing or attempt any repairs.



All applicable local codes and regulations apply to proper installation of this product.

Personal Safety

- Always disconnect the product from the power source before cleaning.
- Always connect the product to a grounded circuit to avoid the risk of electrocution.
- Do not touch the product's housing when operating because it may be very hot.
- Do not drink the fluid.
- Do not allow the fluid to touch the skin or eyes.
- Do not use for space heating purposes.
- Do not touch the output nozzle on this product. It is very hot during operation, and it may remain hot for several hours after turning the product off.

Mounting and Rigging

- This product is for indoor use only! To prevent risk of fire or shock, do not expose this product to rain or moisture. (IP20)
- CAUTION: When transferring product from extreme temperature environments, (e.g., cold truck to warm, humid ballroom) condensation may form on the internal electronics of the product. To avoid causing a failure, allow product to fully acclimate to the surrounding environment before connecting it to power.
- Mount this product in a location with adequate ventilation, at least 20 in (50 cm) from adjacent surfaces.
- Make sure there are no flammable materials close to the product when operating.
- When hanging this product, always secure to a fastening device using a safety cable.
- Only use the handles to carry this product.

Power and Wiring

- Make sure the power cord is not crimped or damaged.
- Always make sure user is connecting this product to the proper voltage in accordance with the specifications in this manual or on the product's specification label.
- To eliminate unnecessary wear and improve its lifespan, during periods of non-use completely disconnect the product from power via breaker or by unplugging it.
- Never connect this product to a dimmer pack or rheostat.
- Never disconnect this product by pulling or tugging on the power cable.

Operation

- Drain the tank before transporting the product.
- Only use Chauvet (PHF) haze fluid or Grignard Pure.
- Do not add anything to the fluid.
- Do not operate this product if there is damage on the housing, hose, or cables. Have the damaged parts replaced by an authorized technician at once.
- The maximum ambient temperature is 113 °F (45 °C). Do not operate the product at higher temperatures.
- The minimum startup temperature is -4°F (-20°C). Do not start the product at lower temperatures.
- The minimum ambient temperature is 50°F (10°C). Do not operate the product at lower temperatures.
- In the event of a serious operation problem, stop using this product immediately!



If the Chauvet product requires service, contact Chauvet Technical Support.

2. Introduction

Description

The AmHaze ECO is a professional water-based haze machine that delivers high output while utilizing economic fluid consumption. With a 30-second heat up time and continuous output that doesn't require reheating, a single fluid container at the maximum output of 120 cfm will last over 8 hours. Easily control the output and fan speed via DMX or on the on-board control knobs. The AmHaze ECO comes ready to rest on the floor and is also equipped with M12 threaded inserts for truss clamps, an easy way to mount the 25 lb machine. The AmHaze ECO combines high output with efficient operation for a complete atmosphere solution for medium to large venues.

Features

- Professional water-based haze machine
- 30-sec heat-up time nearly eliminates wait time for operation
- Continuous output with no reheating required
- Tour-ready with M12 threaded insert for truss clamps
- Efficient fluid consumption lasts more than 8 hours on a single fluid container
- Achieve continuous variable haze output and blower speed, adjusted via DMX or manual knobs

Product Overview

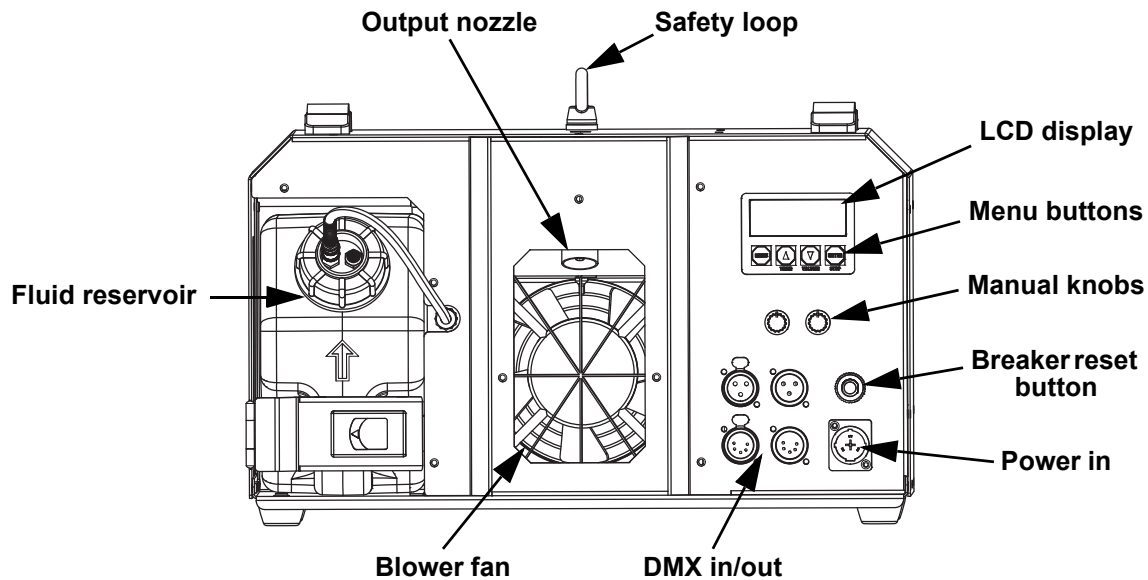

Product Dimensions

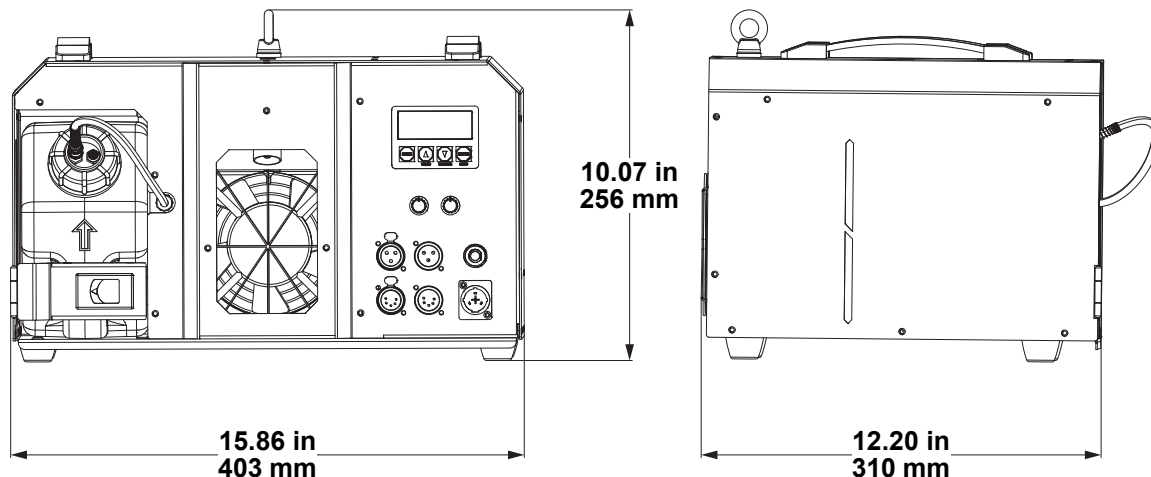

3. Setup

AC Power

The AmHaze ECO has a fixed power supply that works with an input voltage of either 120 VAC, 60 Hz or 230 VAC, 50 Hz, depending on the specific model.

To determine the product's power requirements (circuit breaker, power outlet, and wiring), use the current value listed on the label affixed to the product's back panel, or refer to the product's specifications chart. The listed current rating indicates the product's average current draw under normal conditions.



- **Always connect the product to a protected circuit (a circuit breaker or fuse). Make sure the product has an appropriate electrical ground to avoid the risk of electrocution or fire.**
- **To eliminate unnecessary wear and improve its lifespan, during periods of non-use completely disconnect the product from power via breaker or by unplugging it.**



Never connect the product to a rheostat (variable resistor) or dimmer circuit, even if the rheostat or dimmer channel serves only as a 0 to 100% switch.

AC Plug

The AmHaze ECO comes with a power input cord terminated with a Seetronic Powerkon A connector on one end and an Edison plug on the other end (U.S. market). If the power input cord that came with the product has no plug, or if the user needs to change the plug, use the table below to wire the new plug.

Connection	Wire (U.S.)	Wire (Europe)	Screw Color
AC Live	Black	Brown	Yellow or Brass
AC Neutral	White	Blue	Silver
AC Ground	Green/Yellow	Green/Yellow	Green

Resetting the Breaker

This product is equipped with a resettable circuit breaker. If the breaker trips, all sections of this product will lose power.

1. Remove the power cord from main power.
2. Allow unit to cool for 15 minutes.
3. After 15 minutes, user may attempt to reset the breaker by pressing the button with their finger.
4. Plug the product's power cord into the power outlet and continue using as recommended.

DMX Linking

The AmHaze ECO can link to a DMX controller using a 3-pin or 5-pin DMX connection. If using other DMX-compatible products with this product, user can control each individually with a single DMX controller.

DMX Personalities

The AmHaze ECO uses a 3-pin or 5-pin DMX data connection for the 3-channel DMX personality.



For more information about DMX standards, Master/Slave connectivity, or the DMX cables needed to link this product to a DMX controller, download the DMX Primer from the Chauvet website: www.chauvetprofessional.com.

Remote Device Management (RDM)

Remote Device Management, or RDM, is a standard for allowing DMX-enabled devices to communicate bi-directionally along existing DMX cabling. Check the DMX controller's User Manual or with the manufacturer as not all DMX controllers have this capability. The AmHaze ECO supports RDM protocol that allows feedback to make changes to menu map options.

Setup

Mounting

Before mounting the product, read and follow the safety recommendations indicated in the [Safety Notes](#). For our Chauvet Professional line of mounting clamps, go to <http://trusst.com/products/>.

Orientation

Always mount this product in a safe position, making sure there is adequate room for ventilation, configuration, and maintenance.

Rigging

Chauvet recommends using the following general guidelines when mounting this product.

- Before deciding on a location, always make sure there is easy access to the product for maintenance and programming.
- Mount the product on a structure or surface that can support the product's weight. See the [Technical Specifications](#) for weight information.
- Always use a safety cable when mounting the product overhead.
- Use a mounting clamp of appropriate weight capacity when rigging the product onto truss.

Procedure

The AmHaze ECO comes with a bracket to which users can directly attach mounting clamps. Mounting clamps are sold separately. Make sure the clamps are capable of supporting the weight of this product. Use at least two mounting points per product. For the Chauvet Professional line of mounting clamps, go to <http://www.trusst.com/products>.

Mounting Diagram

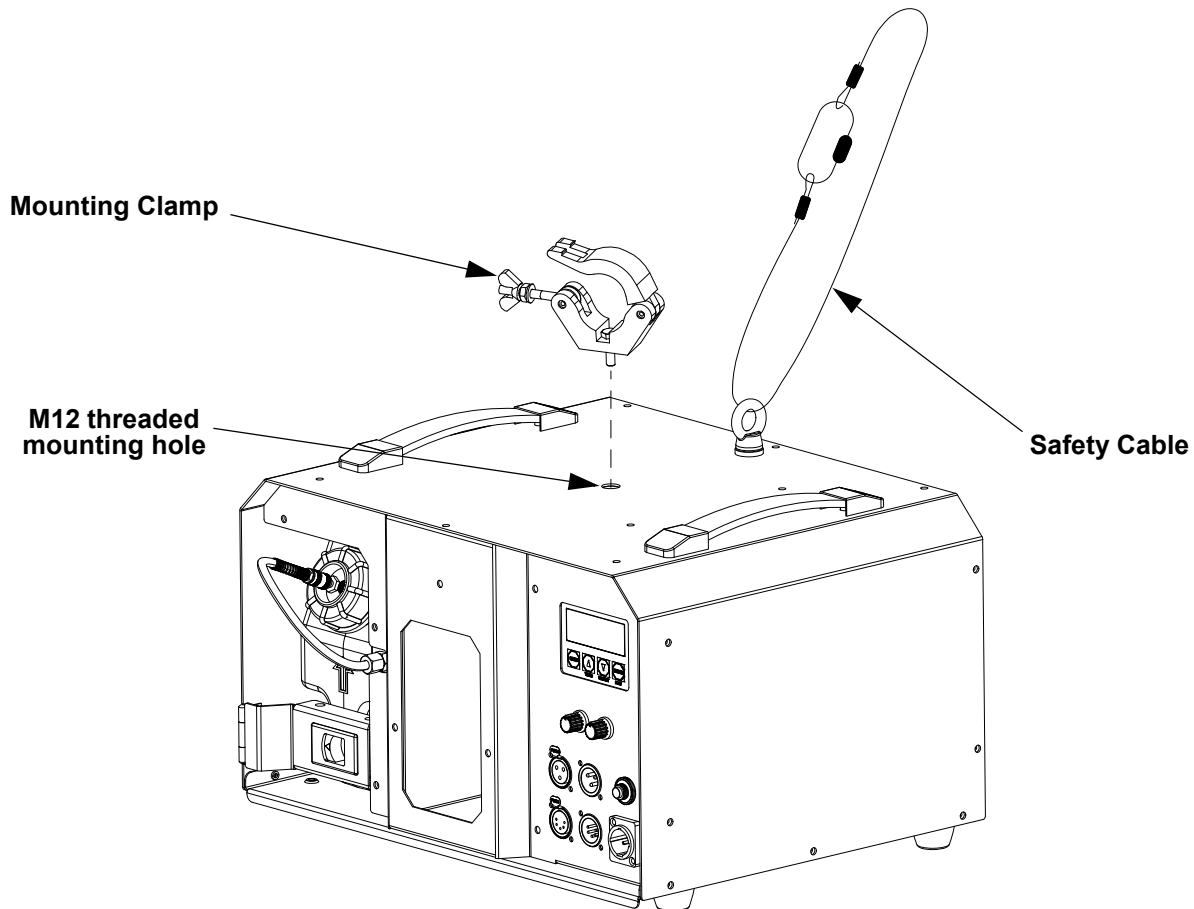

4. Operation

Control Panel Description

Button	Function
<MENU>	Exits from the current menu or function
<UP/TIMER>	UP navigates upwards through the menu list and increases the numeric value when in a function. TIMER starts the timer controlled operation.
<DOWN/VOLUME>	DOWN navigates downwards through the menu list and decreases the numeric value when in a function. VOLUME triggers the pump to modify the output volume.
<ENTER/STOP>	ENTER enables the currently displayed menu or sets the currently selected value into the selected function. STOP turns the fog output off.
HAZE FAN knob	Manually controls the fan speed, 0–100%
HAZE VOLUME knob	Manually controls the haze volume, 0–100%

Control Options

Set the AmHaze ECO starting address in the 001–510 DMX range. This enables control of up to 170 products.

Programming

Refer to the Menu Map to understand the menu options. The menu map shows the main level and a variable number of programming levels for each option.

- To go to the desired main level, press <MENU> repeatedly until the option shows on the display. Press <ENTER> to select. The first programming level for that option will show on the display.
- To select an option or value within the current programming level, press <UP> or <DOWN> until the option shows on the display. Press <ENTER> to select. The selected value or the first option of the next programming level will show on the display.
- Press <MENU> repeatedly to exit to the previous main level.

Menu Map

Refer to the AmHaze ECO product page on www.chauvetprofessional.com for the latest menu map.

Main Level	Programming Levels	Description
Haze Output	1–100%	Haze volume 1–100%
Fan Speed	1–100%	Fan speed (slow to fast)
Timer Interval	5–600S	Sets the interval of haze outputs
Timer Duration	5–300S	Sets the duration of the haze output
DMX Address	1–512	Selects the DMX starting address
RDM-UID	-----	Unique identification number
Fluid Sensor	ON	Turns the fluid sensor ON or OFF
	OFF	
Auto Run Last Setting	YES	Automatically set the values to previous selections
	NO	
Self-Clean & Shutdown	YES	Self-clean mode will begin counting down from 180 seconds to 4 seconds, then shut down after 3 seconds
	NO	
Auto Shutdown	ON	Turns off all functions
	OFF	

Operation

RDM Chart

Refer to the AmHaze ECO product page on www.chauvetprofessional.com for the latest RDM chart.

Category	RDM Parameter ID's (Slots 21-22)	Value	Required	GET Allowed	SET Allowed	Chauvet	Detail
Network Management	DISC_UNIQUE_BRANCH	0x0001	✓			✓	
	DISC_MUTE	0x0002	✓			✓	
	DISC_UN_MUTE	0x0003	✓			✓	
	PROXIED_DEVICES	0x0010		✓			
	PROXIED_DEVICE_COUNT	0x0011		✓			
	COMMS_STATUS	0x0015		✓	✓		
Status Collection	QUEUED_MESSAGE	0x0020		✓		✓	Fluid level Low, Fail to Heat
	STATUS_MESSAGES	0x0030		✓		✓	Temperature
	STATUS_ID_DESCRIPTION	0x0031		✓		✓	
	CLEAR_STATUS_ID	0x0032			✓	✓	
	SUB_DEVICE_STATUS_REPORT_THRESHOLD	0x0033		✓	✓		
RDM Information	SUPPORTED_PARAMETERS	0x0050	✓	✓		✓	
	PARAMETER_DESCRIPTION	0x0051	✓	✓		✓	
Product Information	DEVICE_INFO	0x0060	✓	✓		✓	
	PRODUCT_DETAIL_ID_LIST	0x0070		✓			
	DEVICE_MODEL_DESCRIPTION	0x0080		✓			Amhaze ECO
	MANUFACTURER_LABEL	0x0081		✓			Chauvet Professional
	DEVICE_LABEL	0x0082		✓	✓		Amhaze ECO
	FACTORY_DEFAULTS	0x0090		✓	✓	✓	
	LANGUAGE_CAPABILITIES	0x00A0		✓			
	LANGUAGE	0x00B0		✓	✓		
	SOFTWARE_VERSION_LABEL	0x00C0	✓	✓			
	BOOT_SOFTWARE_VERSION_ID	0x00C1		✓			
	BOOT_SOFTWARE_VERSION_LABEL	0x00C2		✓			
DMX512 Setup	DMX_PERSONALITY	0x00E0		✓	✓	✓	
	DMX_PERSONALITY_DESCRIPTION	0x00E1		✓		✓	
	DMX_START_ADDRESS	0x00F0	✓	✓	✓	✓	
	SLOT_INFO	0x0120		✓		✓	
	SLOT_DESCRIPTION	0x0121		✓		✓	
	DEFAULT_SLOT_VALUE	0x0122		✓		✓	
	DMX_BLOCK_ADDRESS	0x0140		✓	✓		
	DMX_FAIL_MODE	0x0141		✓	✓	✓	Retain last DMX values Reset all values to DMX-000
	DMX_STARTUP_MODE	0x0142		✓	✓	✓	No function Prime pump
Sensors	SENSOR_DEFINITION	0x0200		✓		✓	Min Value(C) Max Value (C)
	SENSOR_VALUE	0x0201		✓	✓	✓	Display sensor value in C
	RECORD_SENSORS	0x0202			✓		

Category	RDM Parameter ID's (Slots 21-22)	Value	Required	GET Allowed	SET Allowed	Chauvet	Detail
Dimmer Settings	DIMMER_INFO	0x0340		✓			
	MINIMUM_LEVEL	0x0341		✓	✓		
	MAXIMUM_LEVEL	0x0342		✓	✓		
	CURVE	0x0343		✓	✓		
	CURVE_DESCRIPTION	0x0344		✓			
	OUTPUT_RESPONSE_TIME	0x0345		✓	✓		
	OUTPUT_RESPONSE_TIME_DESCRIPTION	0x0346		✓			
	MODULATION_FREQUENCY	0x0347		✓	✓		
MODULATION_FREQUENCY_DESCRIPTION	0x0348		✓				
Power Settings	DEVICE_HOURS	0x0400		✓	✓	✓	Total Runtime for life of product
	LAMP_HOURS	0x0401		✓	✓	✓	Shows the runtime since last cleaning cycle was performed. Resets once Cleaning Cycle has been performed
	LAMP_STRIKES	0x0402		✓	✓		
	LAMP_STATE	0x0403		✓	✓		
	LAMP_ON_MODE	0x0404		✓	✓		
	DEVICE_POWER_CYCLES	0x0405		✓	✓		
Display Settings	BURN_IN	0x0440		✓	✓		
	DISPLAY_INVERT	0x0500		✓	✓	✓	Normal/Inverted 180
Configuration	DISPLAY_LEVEL	0x0501		✓	✓		
	PAN_INVERT	0x0600		✓	✓		
	TILT_INVERT	0x0601		✓	✓		
	PAN_TILT_SWAP	0x0602		✓	✓		
	REAL_TIME_CLOCK	0x0603		✓	✓		
	LOCK_PIN	0x0640		✓	✓		
	LOCK_STATE	0x0641		✓	✓		
LOCK_STATE_DESCRIPTION	0x0642	✓	✓				

Category	RDM Parameter ID's (Slots 21-22)	Value	Required	GET Allowed	SET Allowed	Chauvet	Detail
Network Configuration	LIST_INTERFACES	0x0700		✓			
	INTERFACE_LABEL	0x0701		✓			
	INTERFACE_HARDWARE_ADDRESSES_TYPE1	0x0702		✓			
	IPV4_DHCP_MODE	0x0703		✓	✓		
	IPV4_ZEROCONF_MODE	0x0704		✓	✓		
	IPV4_CURRENT_ADDRESS	0x0705		✓			
	IPV4_STATIC_ADDRESS	0x0706		✓	✓		
	INTERFACE_RENEW_DHCP	0x0707			✓		
	INTERFACE_RELEASE_DHCP	0x0708			✓		
	INTERFACE_APPLY_CONFIGURATION	0x0709	✓		✓		
	IPV4_DEFAULT_ROUTE	0x070A		✓	✓		
	DNS_IPV4_NAME_SERVER	0x070B		✓	✓		
	DNS_HOSTNAME	0x070C		✓	✓		
	DNS_DOMAIN_NAME	0x070D		✓	✓		
Control	IDENTIFY_DEVICE	0x1000		✓	✓	✓	
	RESET_DEVICE	0x1001			✓	✓	Yes/No
	POWER_STATE	0x1010		✓	✓		
	PERFORM_SELFTEST	0x1020		✓	✓	✓	Primes Unit
	SELF_TEST_DESCRIPTION	0x1021		✓			Primes Unit
	CAPTURE_PRESET	0x1030			✓		
	PRESET_PLAYBACK	0x1031		✓	✓		
	IDENTIFY_MODE	0x1040		✓	✓		
	PRESET_INFO	0x1041		✓			
	PRESET_STATUS	0x1042		✓	✓		
	PRESET_MERGEMODE	0x1043		✓	✓		
POWER_ON_SELF_TEST	0x1044		✓	✓			

Configuration (DMX)

Use control configurations to operate the product with a DMX controller.

Starting Address

Each product will respond to a unique starting address from the controller. All products with the same starting address will respond in unison. To set the starting address:

1. Go to the **DMX Address** main level.
2. Select the starting address (1–512).
 - The highest recommended starting address is **510**.

Control Channel Assignments and Values

3-Channel

Channel	Function	Value	Percent/Setting
1	Fan speed	000 ⇔ 010	No function
		011 ⇔ 255	1–100%
2	Haze output	000 ⇔ 010	No function
		011 ⇔ 255	1–100%
3	Remote clean function	000 ⇔ 151	No function
		152 ⇔ 159	Remote clean function
		160 ⇔ 255	Standby mode

Configuration (Standalone)

Haze Output

To adjust the haze output through the display menu:

1. Go to the **Haze Output** level.
2. Increase or decrease the value from **1–100%**.

Fan Speed

To adjust the fan speed through the display menu:

1. Go to the **Fan Speed** level.
2. Increase or decrease the value from **1–100%**.

Timer Interval

To adjust the interval of timed haze outputs through the display menu:

1. Go to the **Timer Interval** level.
2. Increase or decrease the value from **5–600S**.

Timer Duration

To adjust the duration of timed haze outputs through the display menu:

1. Go to the **Timer Duration** level.
2. Increase or decrease the value from **5–300S**.

Configuration (Settings)

RDM-UID

To view the RDM-UID of the product, go to the **RDM-UID** level.

Fluid Sensor

To enable or disable the fluid sensor function:

1. Go to the **Fluid Sensor** level.
2. Select from **ON** or **OFF**.

Auto Run Last Setting

To set the control values to the last ones used:

1. Go to the **Auto Run Last Setting** level.
2. Select from **YES** or **NO**.

Auto Shutdown

To shut all functions down:

1. Go to the **Auto Shutdown** level.
2. Select from **ON** or **OFF**.

Operation

Priming the Pump

The AmHaze ECO features an automatic shut-off function. When the fluid sensor detects no fluid in the hose, the pump automatically shuts off. Sometimes an air bubble can be caught in the hose by the fluid sensor, triggering the auto shut-off. To prevent this, the pump must be primed every time the reservoir is refilled from empty and/or every time the hose runs dry.

To prime the pump and remove all air bubbles:

1. Ensure the filter tip of the hose is fully submerged in the fluid.
2. Run the AmHaze ECO on low haze volume.
3. With two fingers, pinch the hose closed so nothing can pass through.



DO NOT use fingernails or anything which may cut the hose!

4. Keep the hose pinched closed for 20–30 seconds. The pump will make a noise that will slowly get louder.
5. After at least 20–30 seconds, release the hose. Fluid should pass quickly through it, preventing any bubbles from becoming trapped.



The pump must be primed every time the reservoir is refilled, or the hose runs dry.

5. Maintenance

Product Maintenance

Do not allow the haze machine to become clogged. After every 40 hours of continuous operation, use Chauvet Fog Cleaner Quart (FCQ) through the system to prevent the accumulation of particulate matter in the heating element.

The recommended cleaning procedure is as follows.

1. Unplug the product from power.
2. Empty all fluid from the machine.
3. Add cleaning solution to the tank.
4. Connect the product to power and allow it to warm up.
5. Run the unit in a well-ventilated area until the tank is empty.
6. Refill with fluid to continue using the hazer. Run the machine briefly to clear any cleaning solution from the pump and heater.



- **FCQ was specifically developed by Chauvet to clean the AmHaze ECO. Make sure to use FCQ regularly to increase the life of the hazer.**
- **Do not spin the fans using compressed air because it could damage the hazer.**
- **Test-run the AmHaze ECO on a monthly basis to achieve the best performance.**



- **Never operate the machine without fluid.**

Storage

Before storing the product, empty the fluid reservoirs. Cleaning the system prior to storage will help prevent any particles from condensing inside the heating element while not in use.

6. Technical Specifications

Dimensions and Weight

Length	Width	Height	Weight
15.86 in (403 mm)	12.20 in (310 mm)	10.07 in (256 mm)	25 lb (11.4 kg)

Note: Dimensions in inches are rounded.

Power

Power Supply Type	Range	Voltage Selection
Fixed	120 VAC, 60 Hz or 230 VAC, 50 Hz	Fixed

Parameter	120 V, 60 Hz	230 V, 50 Hz
Consumption	1,230 W	2,430 W
Operating Current	10.25 A	10.56 A

Power I/O	U.S./Worldwide	UK/Europe
Power Input Connector	Seetronic Powerkon IP65	Seetronic Powerkon IP65
Power Cord plug	Edison (U.S.)	Local Plug

Operation

Tank Capacity	Fluid Consumption	Maximum Run-Time
0.92 gal (3.5 L)	0.11 gallons/hour (7 ml/min)	8 hours @ full volume

Heat-Up Time	Fan Speed
30 sec	120 cfm

Thermal

Startup Temperature Range	Operating Temperature Range	Cooling System
50 °F to 113 °F (10 °C to 45 °C)	50 °F to 113 °F (10 °C to 45 °C)	Convection

DMX

I/O Connector	Channel Range
3-pin and 5-pin XLR	3

Ordering

Product Name	Item Name	Item Code	UPC Number
AmHaze ECO (120V)	AMHAZEECO	09071502	781462218508
AmHaze ECO (230V)	220AMHAZEECO	09071503	781462218515



UL 499
CSA C22.2 No. 64-10
E115095



CONTACT US

General Information	Technical Support
Chauvet World Headquarters	
Address: 3360 Davie Rd. Davie, FL 33314 Voice: (954) 577-4455 Fax: (954) 929-5560 Toll Free: (800) 762-1084	Voice: (844) 393-7575 Fax: (954) 756-8015 Email: chauvetcs@chauvetlighting.com Website: www.chauvetprofessional.com
Chauvet U.K.	
Address: Pod 1 EVO Park Little Oak Drive, Sherwood Park Nottinghamshire, NG15 0EB UK Voice: +44 (0) 1773 511115 Fax: +44 (0) 1773 511110	Email: UKtech@chauvetlighting.eu Website: www.chauvetprofessional.eu
Chauvet Benelux	
Address: Stokstraat 18 9770 Kruishoutem Belgium Voice: +32 9 388 93 97	Email: BNLtech@chauvetlighting.eu Website: www.chauvetprofessional.eu
Chauvet France	
Address: 3, Rue Ampère 91380 Chilly-Mazarin France Voice: +33 1 78 85 33 59	Email: FRtech@chauvetlighting.fr Website: www.chauvetprofessional.eu
Chauvet Germany	
Address: Bruno-Bürgel-Str. 11 28759 Bremen Germany Voice: +49 421 62 60 20	Email: DEtech@chauvetlighting.de Website: www.chauvetprofessional.eu
Chauvet Mexico	
Address: Av. de las Partidas 34 - 3B (Entrance by Calle 2) Zona Industrial Lerma Lerma, Edo. de México, CP 52000 Voice: +52 (728) 690-2010	Email: servicio@chauvet.com.mx Website: www.chauvetprofessional.mx

Warranty & Returns

For warranty terms and conditions and return information, please visit our website.

For customers in the United States and Mexico: www.chauvetlighting.com/warranty-registration.

For customers in the United Kingdom, Republic of Ireland, Belgium, the Netherlands, Luxembourg, France, and Germany: www.chauvetlighting.eu/warranty-registration.